

SERVICE & MAINTENANCE

The following maintenance procedures should be performed on a regular basis.

The following equipment will be needed:

- Cotton swabs.
- **ISOCOL** Rubbing alcohol.



All of the smart keys will need to be removed, you may remove one at a time or all at once by performing an Emergency Release (ID + PIN+ 9 + ENT)

Inside each key location are two contacts (Figure 1), these contacts may accumulate dirt from the smart keys and they will need to be cleaned periodically. To clean the contacts follow these steps.

- 1) Slightly dampen a cotton swab with rubbing alcohol, insert the cotton swab into the location (Figure 2) and clean any dirt from the contacts that may have accumulated. The contact can be rotated 360 degrees by using a pointed object such as a small screwdriver to get to the dirt that could also be trapped underneath.
- 2) Using a dry cotton swab wipe away any excess dirt or moisture that may still be on the contacts.
- 3) Repeat this procedure for each location in your KeyWatcher.

Before returning the smart keys to the key locations, each smart key will also need to be cleaned. To clean the smart keys follow these steps.

- 1) Slightly dampen a cotton swab with rubbing alcohol, rub the cotton swab against the smart chip (Figure 3) cleaning any dirt that may have accumulated.
- 2) Using a dry cotton swab wipe away any excess dirt or moisture that may still be on the smart chip.
- 3) Repeat this procedure for each smart key.

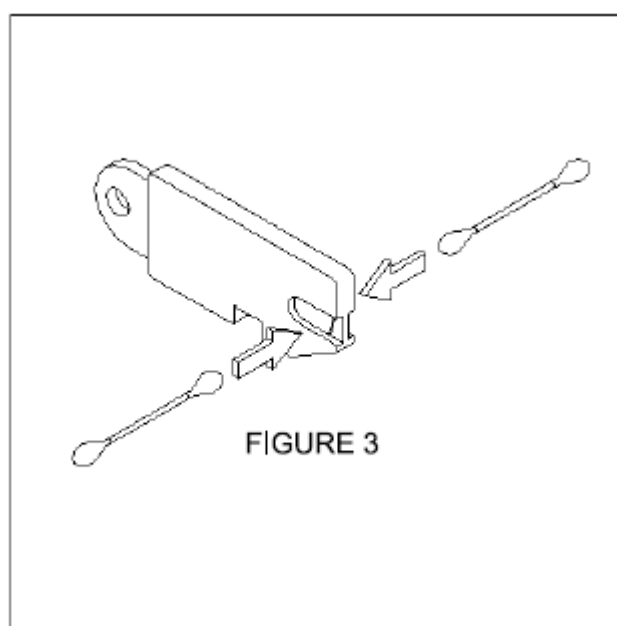
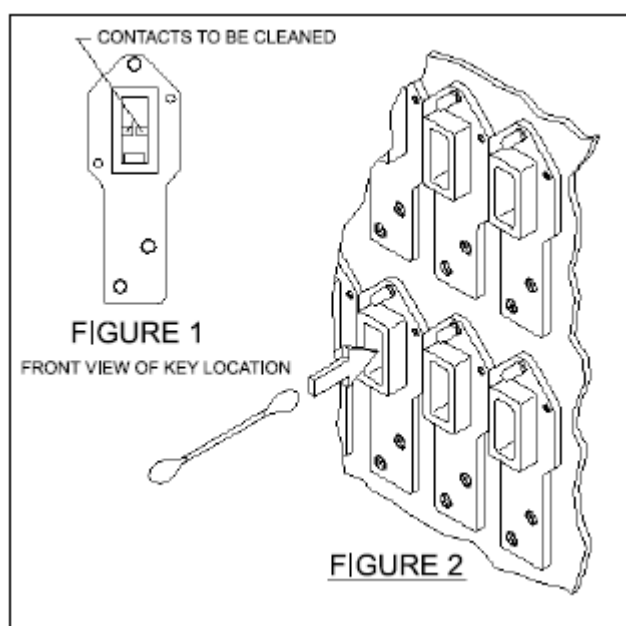

KeyWatch Systems Queensland offers preventative service and maintenance contracts to maintain your system. For further information please contact ally@ksq.com.au 0424331143 for a proposal.